

Focusing on Luxury and Sustainability

September 30, 2024



Meet Our Team



Fabio Salik

President



Hervé Bichon

Vice President Sales,
Beauty & Dispensing Systems



Stéphane Frémiot

European Sales Director,
Beauty & Dispensing Systems



TriMas Packaging Overview



Aarts Packaging



Innovation & Sustainability

TriMas Packaging Overview



TriMas Overview: Our Parent Company

Headquartered in Bloomfield Hills, Michigan, we have operations around the world to serve our global customers.



North America



South America



Europe



Asia



Australia



38

Global Locations



13

Countries



~3,400

Employees



10

Acquisitions
since 2019

TriMas Overview: Our Parent Company

Focused on long-term value creation

LTM⁽¹⁾ Net Sales of \$912M



Advancing our long-term strategy through continue investment in our growing businesses

(1) Last twelve months as of 6/30/24.

TriMas Packaging Overview

Our brands specialize in diverse product offerings across a wide range of end markets

Our Brands



Our Products

Dispensing Systems



Closures



Flexibles



Life Sciences



Our Markets

Beauty &
Personal
Care

Food &
Beverage

Home
Care

Industrial

Life
Sciences

Extensive Global Manufacturing Network

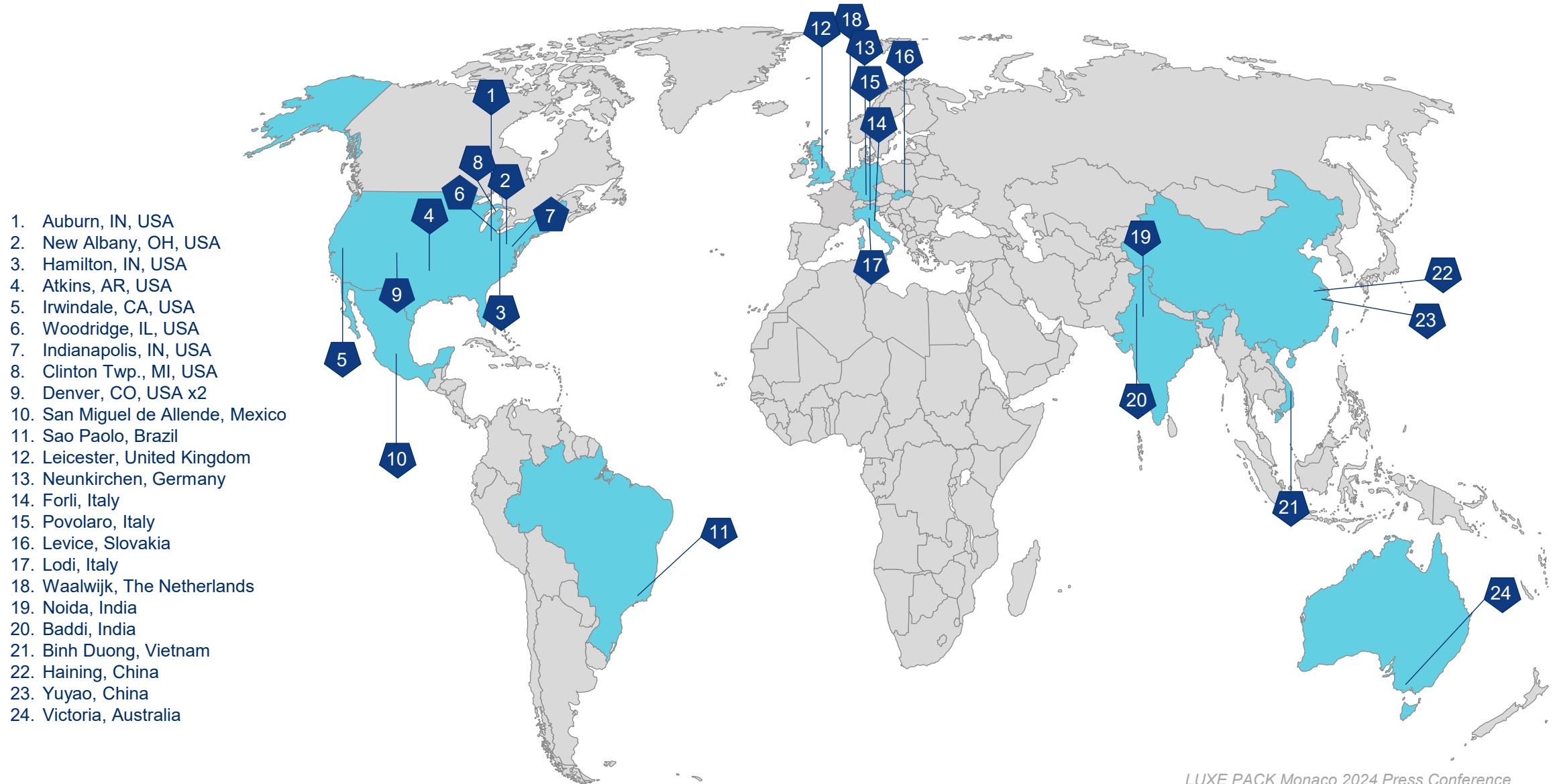

New state-of-the-art facility in Haining, China



New state-of-the-art facility in New Albany, Ohio



Coming in 2025:
New facility in Ho Chi Minh City, Vietnam



Continuing to invest in advanced processes, cutting-edge technology and sustainable innovation

Dispensing Pumps Business Worldwide

Locations

- New Albany, Ohio, USA
- Povolaro, Italy
- Levice, Slovakia
- Leicester, United Kingdom
- Haining, China
- Binh Duong, Vietnam
- Baddi, India
- San Miguel, Mexico

Customers



Products



Locations

- Forlì, Italy
- Povolaro, Italy
- Levice, Slovakia
- Neunkirchen, Germany
- Auburn, Indiana, USA
- Hamilton, Indiana, USA
- San Miguel, Mexico

Customers



Products



Our Powerful Packaging Brands Coming Together

TriMas acquisitions over the years: bringing collective value and benefit to our customers

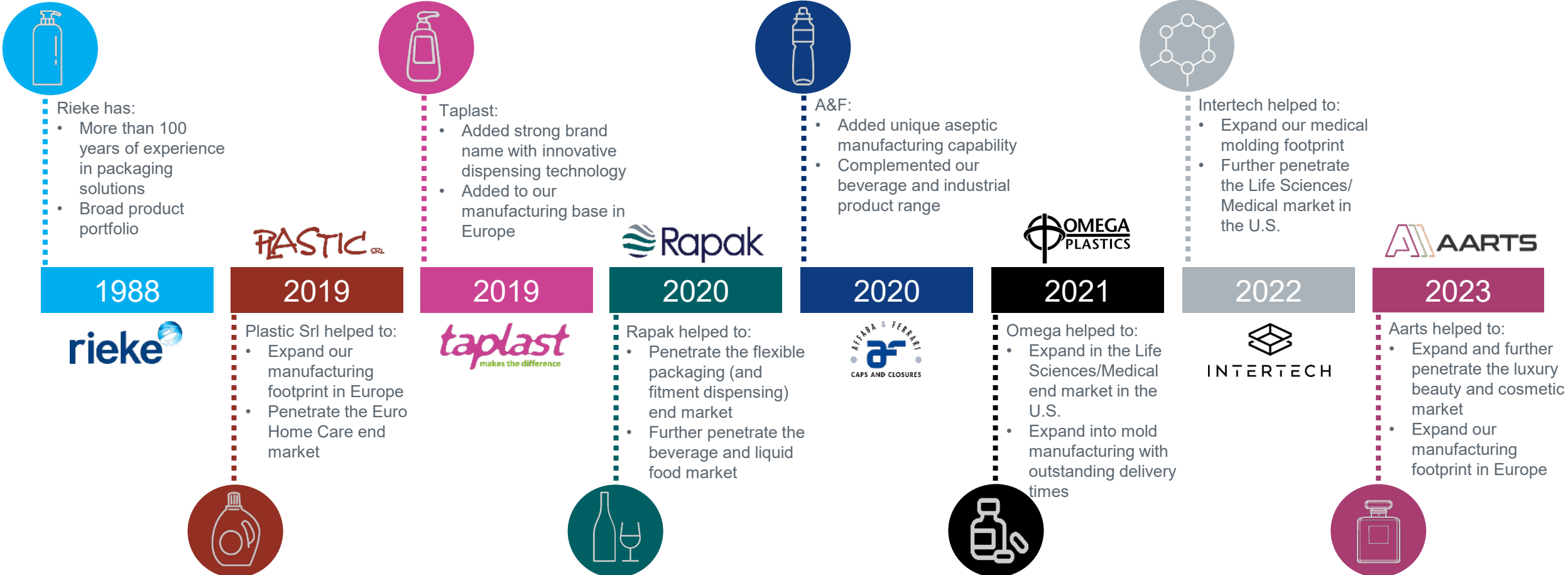

Aarts Packaging: Focusing on Luxury Beauty & Cosmetics



AARTS Packaging
the creative inventors



About Aarts

A new addition to the TriMas Packaging family

■ Background

- Located in Waalwijk, Netherlands
- Founded in 1943
- 25-year track record in packaging
- Acquired by TriMas in 2023

■ Facility

- Over 100,000 sq ft (11.000 m²)
- 40+ injection molding machines: 50 – 330 tons
- 5 bi-injection machines: 160 – 330 tons
- 36 Kawasaki 5 & 6-axis robots



Aarts Packaging

Distinguished innovator for luxury and masstige packaging



PP • High Density PP • Zamac Overmolding • SAN • PS • Tritan • ABS • Surlyn • Metallization

Beauty & Luxury Applications



Caps & Closures
(Fragrance & Liquor)



Lip Gloss



Screw Lids



Compacts



Nail Polish

In-House Capabilities:

- Finishing capabilities, including decorative metallization
- Various fully-automatic assembly lines
- Hot stamping in-line and stand-alone
- Full-color single-pass digital printing
- Mold engineering, tool shop and automation team

Food Applications



**Jars, In-Mold Labeling (IML),
Scoops**

Medical Applications



Jars and Dosing

New Perfume Pump

Expanding our luxury market presence in Europe



- Developed through strategic venture with an Asian partner
- Already approved by several major European brand owners and successfully launched in Brazil
- Available in crimp-on, snap-on and screw-on versions

- Investing in two, soon three, new production lines to support growth
- Annual capacity of 100 million pumps
- Timing: Early 2025

- Leveraging Aarts' injection molding expertise in manufacturing high-end beauty closures
- Positioned to become one of the top producers of this pump type in Europe, offering greater flexibility to our customers

New Crimp-On Perfume Pump

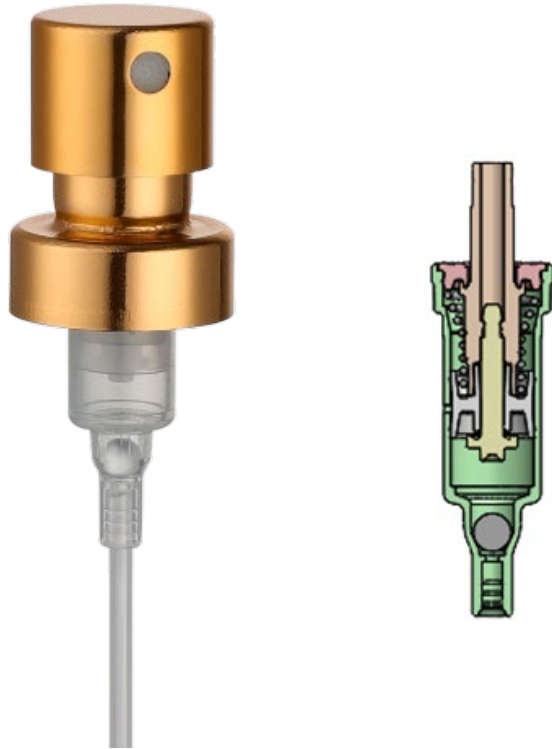

- **High precision** pump performance
 - Meets **market-leading specifications**
 - **Benchmarked** to European and U.S. market equivalents
- **Low profile** design
- **Plastic and aluminum** actuators
- Gasket compatible with **alcohol-based** fragrances
- **FEA 13, 15, 18 and 20mm**
- Meets **all regional regulations**
- Features **transparent dip and glass ball**

New Snap-On Perfume Pump

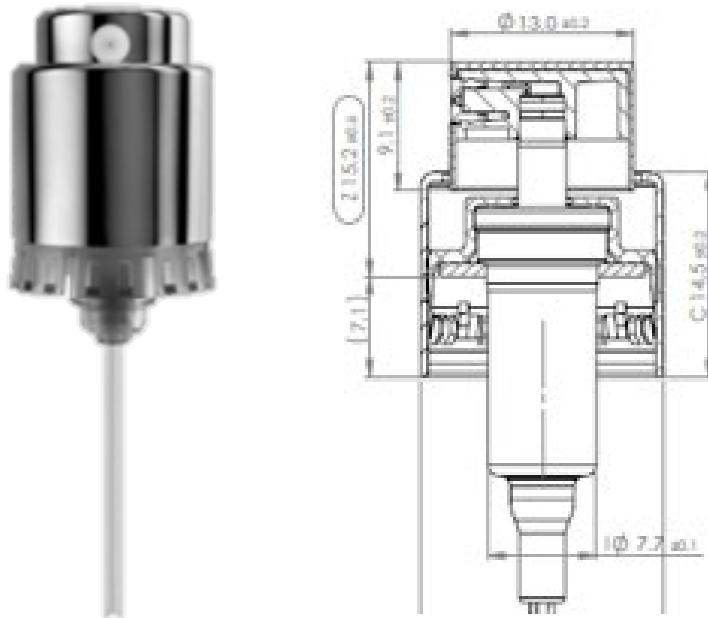

- **High precision** pump performance
 - Meets **market-leading specifications**
 - **Benchmarked** to European and U.S. market equivalents
- **Low profile** design
- **Aluminum** actuator
- Gasket compatible with **alcohol-based** fragrances
- **13 and 15mm** closures
- Meets **all regional regulations**
- Features **transparent dip and glass ball**

New Screw-On Perfume Pump

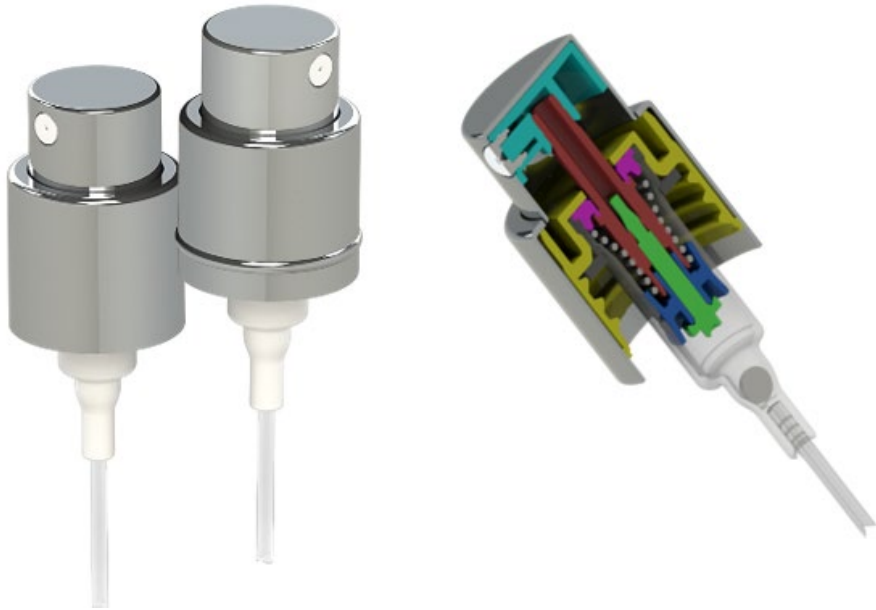

- **High precision** pump performance
 - Meets **market-leading specifications**
 - **Benchmarked** to European and U.S. market equivalents
- **Low profile** design
- **Plastic and metal** actuators
- Gasket compatible with **alcohol-based** fragrances
- **SNI 15mm screw** closures
- Meets **all regional regulations**
- Features **transparent dip and glass ball**

Innovation & Sustainability





Sustainability



Customization & Personalization



E-commerce



Smart & Touchless Packaging



Safety



Assessing industry trends and customer needs to prioritize new product development

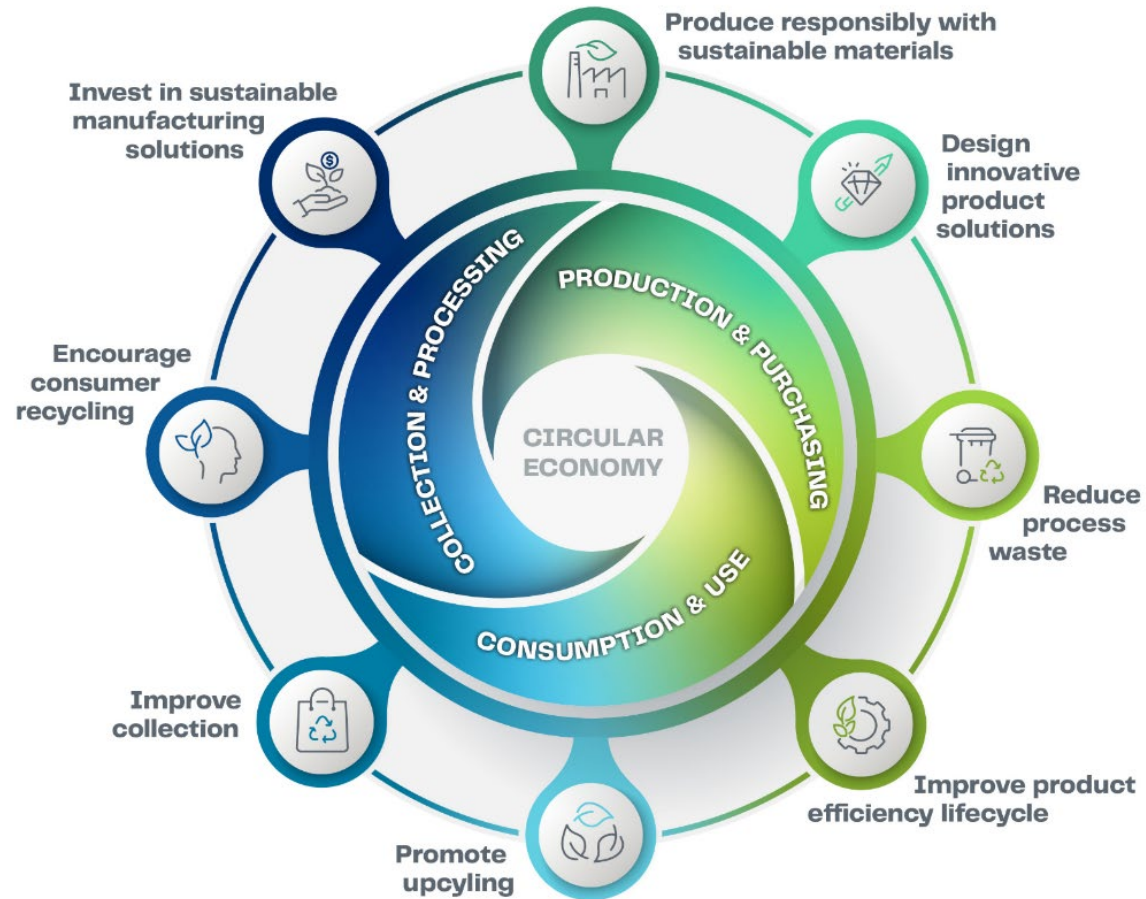

We prioritize understanding the environmental and social impacts of our products. Our approach involves the thoughtful design of products that not only reinforce sustainability principles but also uphold high standards in terms of performance, quality and safety.

Focused on sustainability throughout the entire product lifecycle

Sustainable Certifications:



EcoVadis Gold sustainability rating obtained at our U.S.-based sites. Silver rating obtained at our EU and Asia sites.



International Sustainability & Carbon Certification (ISCC PLUS) at our Povolaro, Italy, facility and in progress at other sites.



ISO 50001 Certified in our German facility.



ISO 14001 Certified at multiple facilities.



ISO 45001 Certified at multiple facilities.



In-house Amazon Approved ISTA 6 labs to reduce wasteful packaging.

We Are Proud Members of:



Sustainable Product Innovation

Single-polymer, all plastic and e-commerce designs for enhanced recyclability



PCR INCLUSION

- Traditional pumps incorporating PCR

E-COMMERCE

- First-of-its-kind Amazon-certified ISTA 6 pumps
- PCR options available

ALL PLASTIC

- Distinctive bellows technology made of 100% plastic (with no metal spring or glass ball)
- 100% recyclable, sustainable

SINGLE MATERIAL & E-COMMERCE

- 100% same material
- 100% recyclable
- Amazon-certified ISTA 6
- Unique look

SINGLE MATERIAL, E-COMMERCE & PCR

- Single-material dispenser pump without compromising quality, aesthetics or performance
- Amazon-certified ISTA 6
- PCR options
- 100% recyclable
- European certified RecyClass 'A rated'

Increasing our sustainable product range and our evolution to *Singolo*[™]: our fully recyclable, single-polymer dispenser.

- Fully-recyclable 2cc dispensing pump with single-polymer material design
- Highly familiar look, feel and functionality to a traditional pump
- Highly customizable to different requirements, formula viscosities and container designs
- European-certified with RecyClass – ‘A rated’
- Compliant by ISTA 6 e-commerce standards
- Suitable for a wide variety of beauty, personal care and home care applications including hand and body soaps, body lotions, hair products and dish soaps
- 4cc and 5cc dosages available in the future



Addressing the key trends of sustainability, customization and e-commerce

Singolo™ All Plastic Foam Pump

Latest offering to our Singolo family of products

- Fully-recyclable foam pump with all plastic design
- Utilizes plastic spring 'butterfly technology' in place of stainless-steel spring
- Highly familiar look, feel and functionality to a traditional foam pump
- Highly customizable to different requirements, formula viscosities and container designs
- The Association of Plastic Recyclers (APR) approved
- Suitable for a wide variety of beauty, personal care and home care applications including hand and body soaps, hair products and dish soaps



Addressing the key trends of sustainability and customization

Thank You Questions?



Visit us at **Booth #RD10** in the Ravel Hall

Contact Us

 Packaging-Marketing@trimas.com

 www.trimaspackaging.com

